

3-WAY BALL VALVE THREADED DN 10 – 50 PN 63

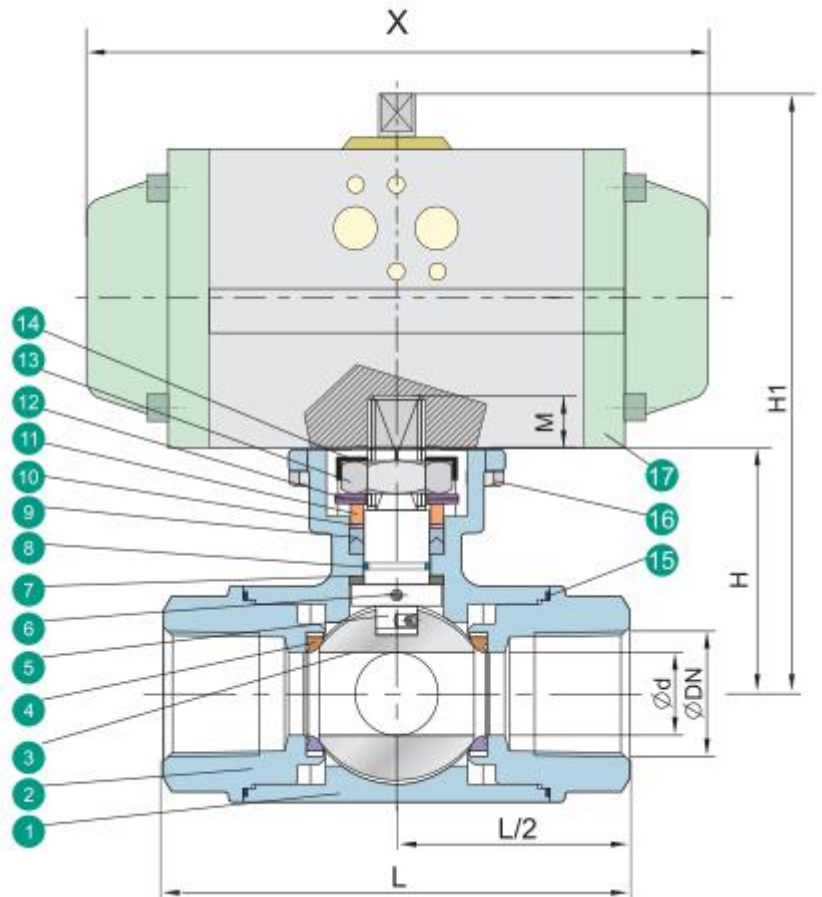

Description

- DN10-DN50 PN63
- 3-Way ball valve - threaded
- TA-LUFT design approved
- Built-in ISO 5211 Mounting-Pad for easy automation
- quality and precision castings
- flowing ball valve
- bull bore
- blow-out proof stem

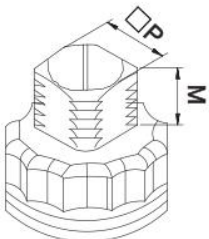
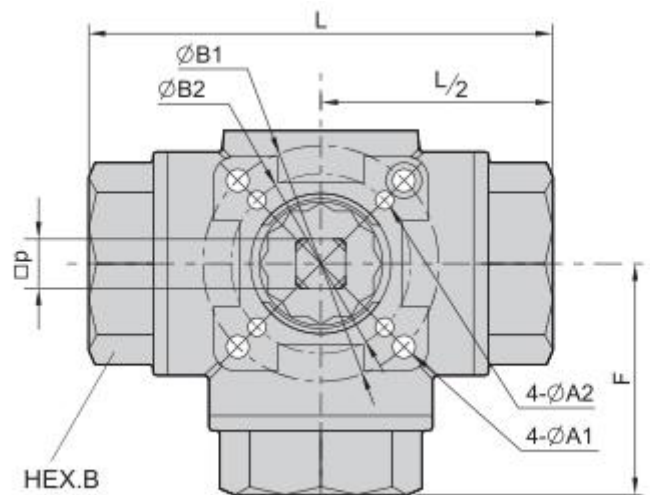
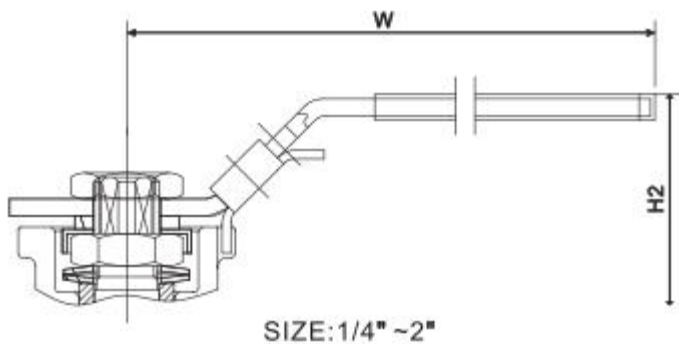

3-WAY BALL VALVE THREADED DN 10 – 50 PN 63

Sizes

DN	ød	L	H	H1	H2	W	M	F	øB1	øB2	øA1	øA2	P	HEX.B	X	ISO5211
8	11	79	42	139	70	147	9	40	42	36	6	6	9	27	144	F03-F04
10	11	79	42	139	70	147	9	40	42	36	6	6	9	27	144	F03-F04
15	11	79	42	139	70	147	9	40	42	36	6	6	9	27	144	F03-F04
20	15	88	49	146	77	147	9	44	50	36	7	6	9	34	144	F03-F05
25	20	108	60	188	87	177	11	54	50	42	7	6	11	41	208	F04-F05
32	25	124	63	191	93	177	11	62	70	42	9	6	11	50	208	F04-F07
40	32	135	74	216	103	215	14	68	70	50	9	7	14	56	247	F05-F07
50	40	164	83	225	113	215	14	82	70	50	9	7	14	70	247	F05-F07

Components

No.	Part name	Material		
1	Body	CF8M	CF8	WCB
2	Cap	CF8M	CF8	WCB
3	Ball	CF8M	CF8	
4	Seat	TFM1600/PTFE/RTFE		
5	Stem	SUS316	SUS304	
6	Anti-static Device	SUS316	SUS304	
7	Thrust Washer	PTFE		
8	O-Ring	FKM		
9	Stem packing	PTFE		
10	Bushing	50%SS + 50% PTFE		
11	Gland	SUS316		
12	Belleville Washer	SUS301		
13	Stem Nut	A194-8		
14	Stop-lock cap	SUS304		
15	Body Gasket	PTFE		
16	Hex Bolting	A193-B8		
17	Actuator	Pneumatic/Electric		