



Description

- three-pieces design
- investment castings
- floating balls compensating wear-out and temperature dilatation
- full-port
- anti-blow-out stem
- material stainless steel and carbon steel

Assembly

- in any position

Types

50-100 threaded



50-500 flanged



50-300 welded



BALL VALVE THREE-PIECES DESIGN SERIES 50 – ECONOMICAL VERSION DN 10 – 50 PN 63; DN 65 – 100 PN 40

DN 10 - 50

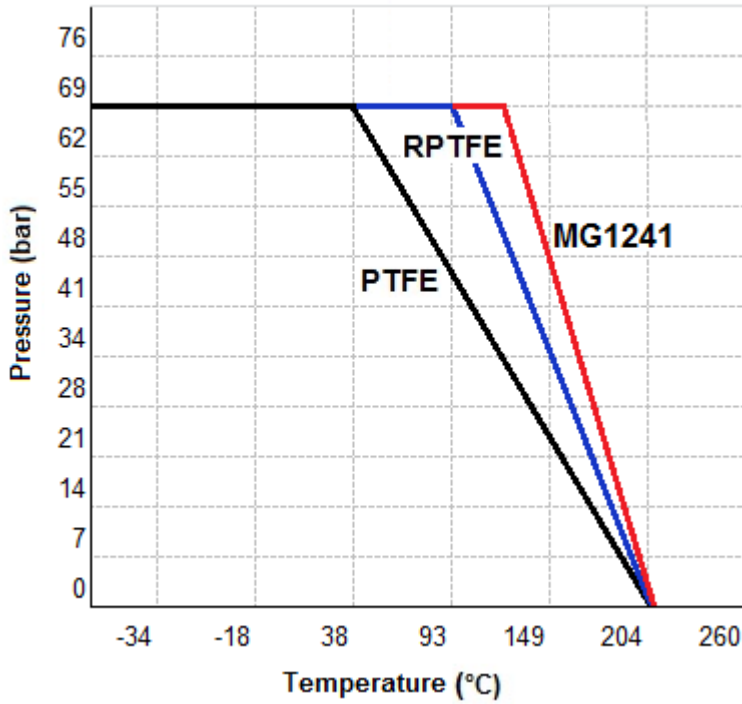

DN 65 – 100

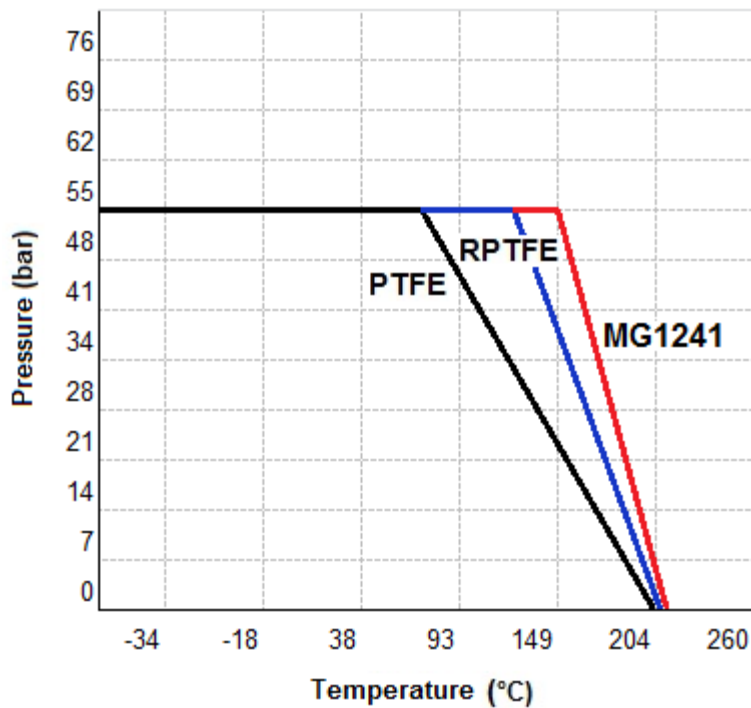

BALL VALVE THREE-PIECES DESIGN SERIES 50 – ECONOMICAL VERSION DN 10 – 50 PN 63; DN 65 – 100 PN 40

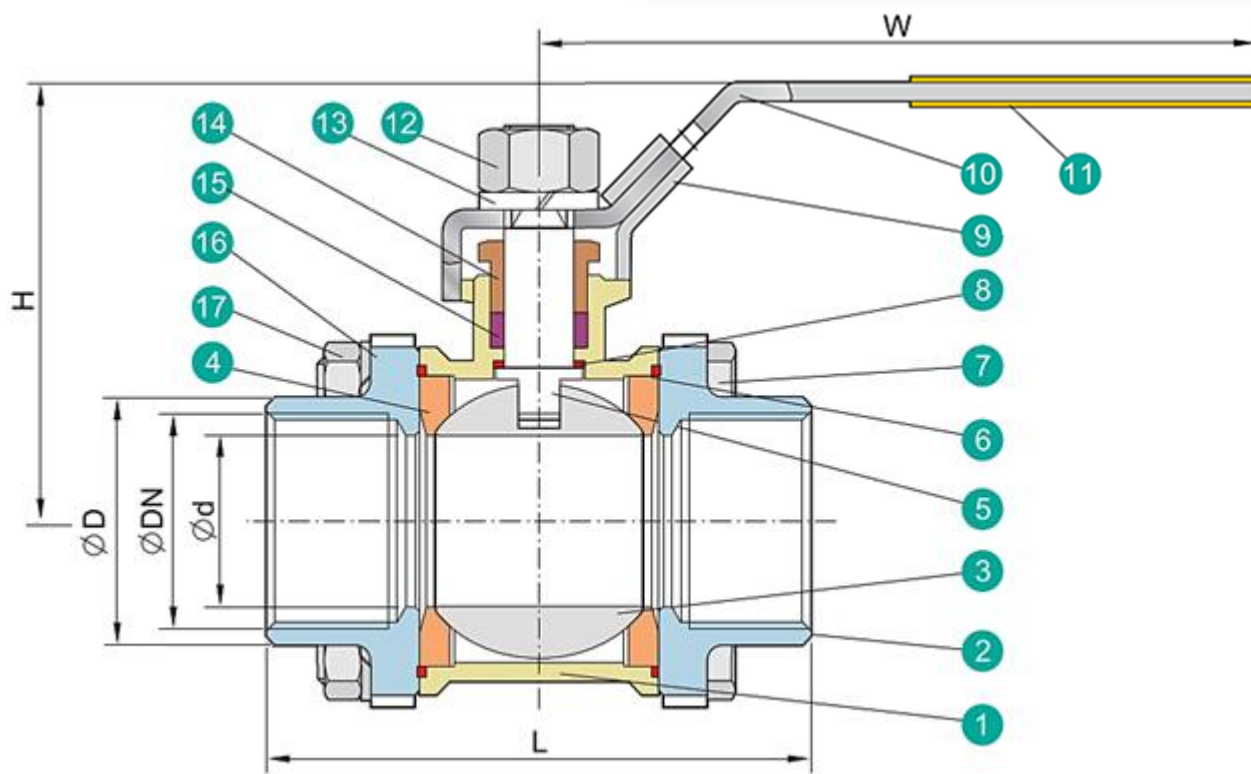

No.	Part name	Materials		
1	Body	CF8M	CF8	WCB
2	Cap (Thread)	CF8M	CF8	WCB
	Cap (Welding)	CF3M		
3	Ball	CF8M	CF8	
4	Ball Seat	PTFE		
5	Stem	SUS 316	SUS 304	
6	Body Gasket	PTFE		
7	Bolt	A193-B8		
8	Thrust Washer	PTFE		
9	Locking device	SUS 304		
10	Lever	SUS 304		
11	Lever Sleeve	VINYL PLASTIC		
12	Stem Nut	A194-8		
13	Stem Washer	SUS 304		
14	Gland Nut	SUS 304		
15	V-Ring Packing	PTFE		
16	Bolt Washer	SUS 304		
17	Bolt Nut	A194-8		



Elišky Přemyslovny 1343
156 00 Praha 5, mapol@iol.cz

tel: +420 257 921 545, fax: +420 257 921 659

**BALL VALVE
THREE-PIECES DESIGN
SERIES 50 – ECONOMICAL VERSION
DN 10 – 50 PN 63; DN 65 – 100 PN 40**

Dimensions (mm)

DN	Ød	ØD	L	H	W
10	10	17,0	70	56	102
15	15	21,3	75	65	123
20	20	26,7	90	67	123
25	25	33,6	100	79	153
32	32	42,4	110	84	153
40	38	48,0	125	92	183
50	50	60,5	150	99	183
65	65	76,1	190	136	246
80	80	88,9	220	146	246
100	100	114,2	270	168	503