

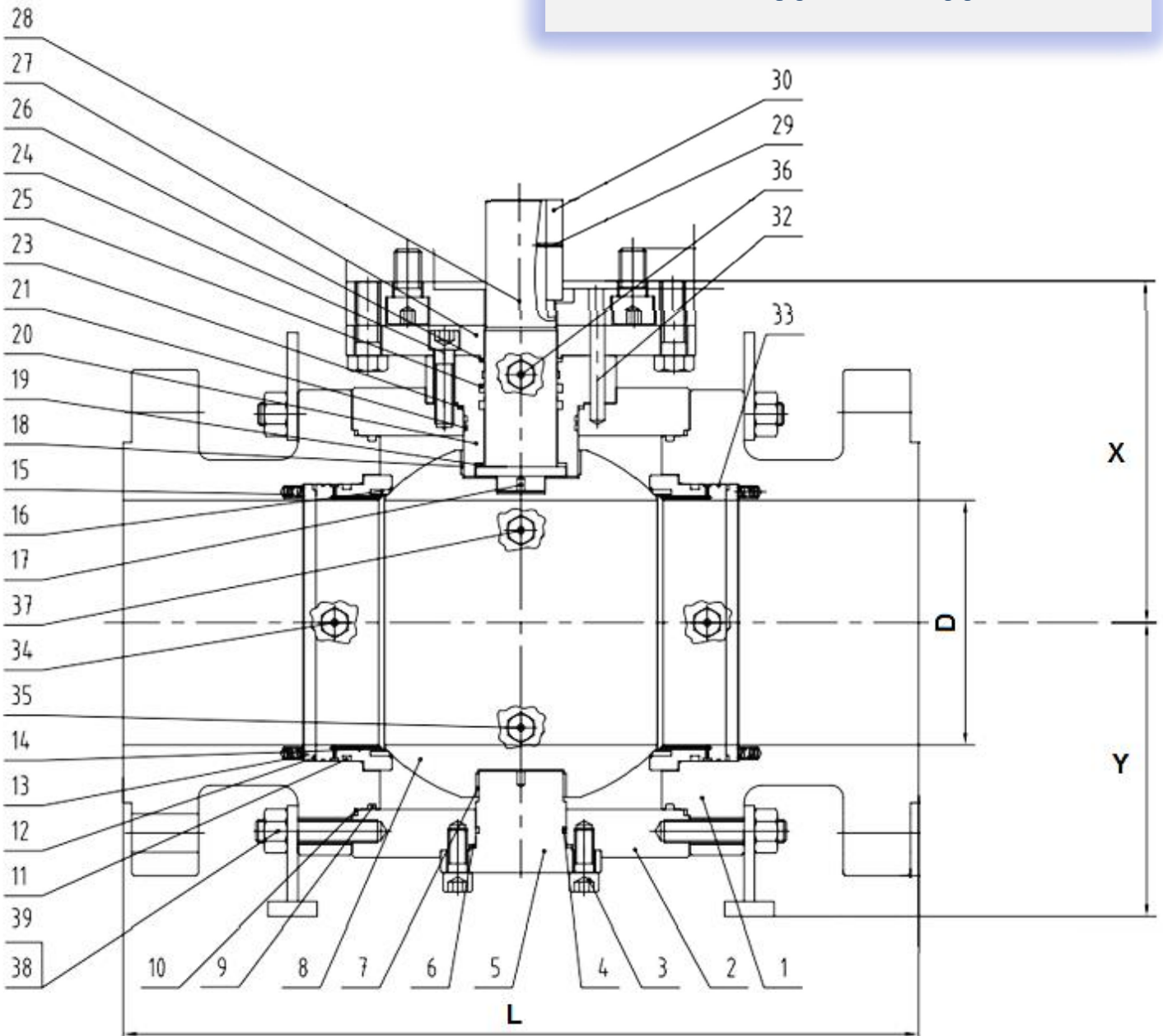

Elišky Přemyslovny 1343
156 00 Praha 5, mapol@iol.cz
tel: +420 257 921 545, fax: +420 257 921 659

BALL VALVE
TYPE HTP
Full bore
CLASS 150-2500
DN50 - DN1400





Elišky Přemyslovny 1343
156 00 Praha 5, mapol@iol.cz
tel: +420 257 921 545, fax: +420 257 921 659

BALL VALVE
TYPE HTP
Full bore
CLASS 150-2500
DN50 – DN1400

Components

No.	Part	Material	No.	Part	Material
1	End body	A350 LF2	20	Gland	AISI 4140+ENP
2	Body	A350 LF2	21	O-Ring	VITON
3	Bolt	A320 L7	23	Gasket	GRAPHITE+304
4	O-Ring	VITON	24	Bolt	A320 L7
5	Trunnion	A350 LF2+ENP	25	O-Ring	VITON
6	Gasket	GRAPHITE+304	26	Gasket	GRAPHITE
7	Bearing	CS+PTFE	27	Plate	A350 LF2
8	Ball	A350 LF2+STL	28	Stem	AISI 4140+ENP
9	O-Ring	VITON	29	Pin	AISI 1566
10	Gasket	GRAPHITE+304	30	Key	A29 1045
11	O-Ring	VITON	32	Pin	A29 1045
12	Gasket	GRAPHITE+304	33	O-Ring	VITON
13	Spring seat	A350 LF2+ENP	34	Injection valve	A350 LF2
14	Seat	A350 LF2+ENP	35	Drain valve	A350 LF2
15	Spring	INCONEL X750	36	Injection valve	A350 LF2
16	Seat insert	RPTFE	37	Exhaust valve	A350 LF2
17	Spring	A276 316	38	Bolt	A320 L7
18	Bearing	CS+PTFE	39	Nut	A194 4
19	Gasket	PTFE			

Class 150 Full Bore

DN	SIDE ENTRY				WELDED BODY			TOP ENTRY		
	A	X	Y	kg	X	Y	kg	X	Y	kg
50	49	106	102	27	106	102	n/a*	207	85	30
80	74	157	126	54	157	126	n/a*	223	114	57
100	100	198	163	89	198	163	n/a*	280	140	100
150	150	247	187	160	247	187	n/a*	275	219	215
200	201	280	224	253	280	224	n/a*	321	265	407
250	252	320	278	387	320	278	n/a*	355	315	560
300	303	337	306	559	337	306	n/a*	470	405	710
350	334	374	334	760	374	334	n/a*	455	432	760
400	385	408	358	1020	408	358	n/a*	460	451	1100
450	436	439	390	1215	439	390	n/a*	503	472	1512
500	487	492	434	1793	492	434	n/a*	560	560	1930
550	538	528	477	2359	528	477	n/a*	565	591	2750
600	589	588	523	3099	588	523	n/a*	610	600	3200
650	633	627	564	3685	627	564	n/a*	670	632	3800
700	684	644	658	4490	644	658	n/a*	730	710	4600
750	735	691	704	5215	691	704	n/a*	800	790	5630
800	779	742	746	6800	742	746	n/a*	846	830	7085
850	830	759	773	7800	759	773	n/a*	870	880	7800
900	874	812	807	8800	812	807	n/a*	935	933	9100
1000	976	900	898	12560	900	898	n/a*	1012	1030	12790
1050	1020	943	937	14280	943	937	n/a*	1070	1065	15100
1200	1166	1097	1066	21900	1097	1066	n/a*	1190	1230	22600
1400	1360	1302	1253	34100	1302	1253	n/a*	n/a*	n/a*	n/a*



Elišky Přemyslovny 1343
156 00 Praha 5, mapol@iol.cz
tel: +420 257 921 545, fax: +420 257 921 659

BALL VALVE
TYPE HTP
Full bore
CLASS 150-2500
DN50 – DN1400

Class 300 Full Bore

DN	A	SIDE ENTRY			WELDED BODY			TOP ENTRY		
		X	Y	kg	X	Y	kg	X	Y	kg
50	49	100	95	27	100	95	n/a*	211	90	36
80	74	150	120	55	150	120	n/a*	226	119	63
100	100	200	160	92	200	160	n/a*	286	145	106
150	150	245	200	182	245	200	n/a*	282	224	221
200	201	275	230	278	275	230	n/a*	325	270	412
250	252	330	295	500	330	295	n/a*	360	320	566
300	303	355	330	733	355	330	n/a*	475	410	715
350	334	390	345	1029	390	345	n/a*	460	437	766
400	385	430	390	1418	430	390	n/a*	465	456	1106
450	436	455	410	1592	455	410	n/a*	508	477	1519
500	487	500	465	2195	500	465	n/a*	565	565	1936
550	538	525	480	2788	525	480	n/a*	572	596	2756
600	589	590	545	3460	590	545	n/a*	617	605	3208
650	633	630	580	4660	630	580	n/a*	678	637	3808
700	684	640	665	5770	640	665	n/a*	738	715	4607
750	735	700	730	6590	700	730	n/a*	811	795	5638
800	779	745	765	7932	745	765	n/a*	850	835	7092
850	830	760	800	9040	760	800	n/a*	877	885	7811
900	874	805	825	10093	805	825	n/a*	942	938	9112
1000	976	900	920	13775	900	920	n/a*	1020	1036	12798
1050	1020	968	950	16105	968	950	n/a*	1081	1070	15113
1200	1166	1100	1100	24060	1100	1100	n/a*	1201	1236	22614
1400	1360	1285	1270	38155	1285	1270	n/a*	n/a*	n/a*	n/a*



Elišky Přemyslovny 1343
156 00 Praha 5, mapol@iol.cz
tel: +420 257 921 545, fax: +420 257 921 659

BALL VALVE
TYPE HTP
Full bore
CLASS 150-2500
DN50 – DN1400

Class 600 Full Bore

DN	A	SIDE ENTRY			WELDED BODY			TOP ENTRY		
		X	Y	kg	X	Y	kg	X	Y	kg
50	49	102	98	31	102	98	n/a*	215	95	41
80	74	165	128	62	165	128	n/a*	232	124	67
100	100	210	160	113	210	160	n/a*	294	150	110
150	150	250	200	253	250	200	n/a*	287	129	226
200	201	288	255	485	288	255	n/a*	324	275	417
250	252	330	308	758	330	308	n/a*	365	325	570
300	303	378	348	1067	378	348	n/a*	480	415	720
350	334	394	360	1083	394	360	n/a*	465	442	770
400	385	430	410	1525	430	410	n/a*	470	461	1112
450	436	467	430	2095	467	430	n/a*	512	482	1523
500	487	500	492	2638	500	492	n/a*	570	570	1940
550	538	950	505	3787	950	505	n/a*	578	602	2760
600	589	594	570	4736	594	570	n/a*	622	610	3213
650	633	630	618	5647	630	618	n/a*	682	640	3813
700	684	665	692	6758	665	692	n/a*	742	722	4612
750	735	741	800	8377	741	800	n/a*	817	804	5640
800	779	756	804	9738	756	804	n/a*	855	840	7103
850	830	782	817	11336	782	817	n/a*	893	890	7822
900	874	869	945	13298	869	945	n/a*	847	944	9118
1000	976	916	980	18335	916	980	n/a*	1025	1041	12805
1050	1020	995	1110	21356	995	1110	n/a*	1086	1075	15118
1200	1166	1132	1265	31195	1132	1265	n/a*	1506	1240	22619
1400	1360	1290	1450	47483	1290	1450	n/a*	n/a*	n/a*	n/a*

Class 900 Full Bore

DN	A	SIDE ENTRY			WELDED BODY			TOP ENTRY		
		X	Y	kg	X	Y	kg	X	Y	kg
50	49	104	103	48	104	103	n/a*	212	85	52
80	74	163	132	55	163	132	n/a*	227	113	110
100	100	211	169	145	211	169	n/a*	277	144	200
150	150	259	213	360	259	213	n/a*	283	333	430
200	201	297	264	580	297	264	n/a*	334	274	800
250	252	342	333	1010	342	333	n/a*	380	320	1000
300	303	384	379	1510	384	379	n/a*	507	418	1300
350	322	398	368	1450	398	368	n/a*	520	443	1695
400	373	436	437	2150	436	437	n/a*	538	462	2560
450	423	484	497	2820	484	497	n/a*	580	487	3400
500	471	532	503	4200	532	503	n/a*	625	605	4400
600	570	617	633	6800	617	633	n/a*	690	625	7200
700	665	674	706	9900	674	706	n/a*	820	723	10400
750	712	723	777	12180	723	777	n/a*	880	800	12875
800	760	784	809	11820	784	809	n/a*	938	870	15950
850	808	807	852	17200	807	852	n/a*	982	920	17500
900	855	848	898	18900	848	898	n/a*	1050	990	20600



Elišky Přemyslovny 1343
156 00 Praha 5, mapol@iol.cz
tel: +420 257 921 545, fax: +420 257 921 659

BALL VALVE
TYPE HTP
Full bore
CLASS 150-2500
DN50 – DN1400

Class 1500 Full Bore

DN	A	SIDE ENTRY			WELDED BODY			TOP ENTRY		
		X	Y	kg	X	Y	kg	X	Y	kg
50	49	106	104	50	106	104	n/a*	212	87	56
80	74	167	128	97	167	128	n/a*	236	118	153
100	100	179	170	198	179	170	n/a*	294	150	278
150	144	260	233	480	260	233	n/a*	303	236	600
200	192	304	290	820	304	290	n/a*	354	285	1100
250	239	363	352	1500	363	352	n/a*	398	333	1438
300	287	417	425	2250	417	425	n/a*	520	427	2017
350	315	437	426	2850	437	426	n/a*	550	456	2612
400	360	475	493	4070	475	493	n/a*	565	487	3890
450	405	563	608	6195	n/a*	n/a*	n/a*	592	527	5100
500	455	617	645	9075	n/a*	n/a*	n/a*	650	630	6678
600	530	698	724	14280	n/a*	n/a*	n/a*	660	640	11700

Class 2500 Full Bore

DN	A	SIDE ENTRY			TOP ENTRY		
		X	Y	kg	X	Y	kg
50	42	120	127	88	212	98	120
80	62	177	198	187	243	122	246
100	87	227	233	380	299	164	470
150	131	264	252	770	355	243	937
200	179	383	339	1357	424	292	1410
250	223	453	422	2100	503	352	2600
300	265	520	482	3210	588	436	4200