



### Description

- one-directional knife gate valve
- simple installation due to the short face-to-face dimension
- with rising stem or with non-rising stem
- **3 types execution:** - WAFER  
- LUG  
- FLANGE
- **assembly:** vertically or horizontally between flanges PN2,5/10/16/25
- **operation:** handwheel, pneumatic actuator, electric actuator
- maintenance free
- design ensures flushing sealing area of the slide
- self cleaning design
- full bore design

## KNIFE GATE VALVE Type SGV DN80 – 3000, PN2,5-25

### Components - Specification

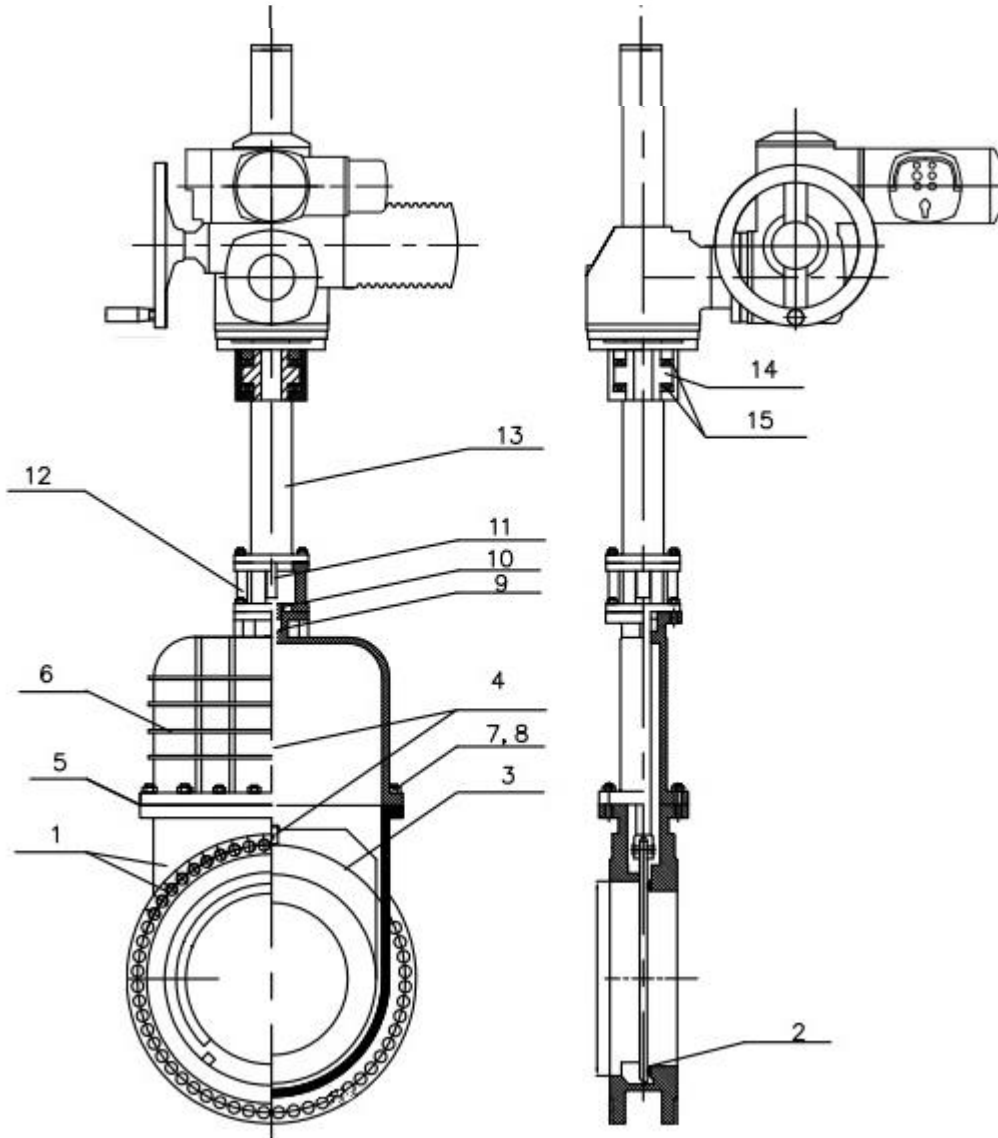

#	Part	Material
1	Body	SUS304 / CF8
2	Seat	SS304
3	Knife	SS304
4	Stem	ASTM A182 F304
5	Gasket	Graphite+SS304
6	Cover	SUS304 / CF8
7	Bolts . cover	ASTM A193 CF8
8	Nut . cover	ASTM A194 B8

#	Part	Material
9	Shaft seal	Graphite
10	Packing	ASTM A351 CF8
11	Packing bolt	ASTM A193 B8
12	Yoke	SUS304 / CF8
13	Extension	Carbon steel
14	Shaft nuts	Bronze
15	Bearing	1Cr15