

3-WEGE KUGELHAHN (Schweissen) DN 10 – 50 PN 63

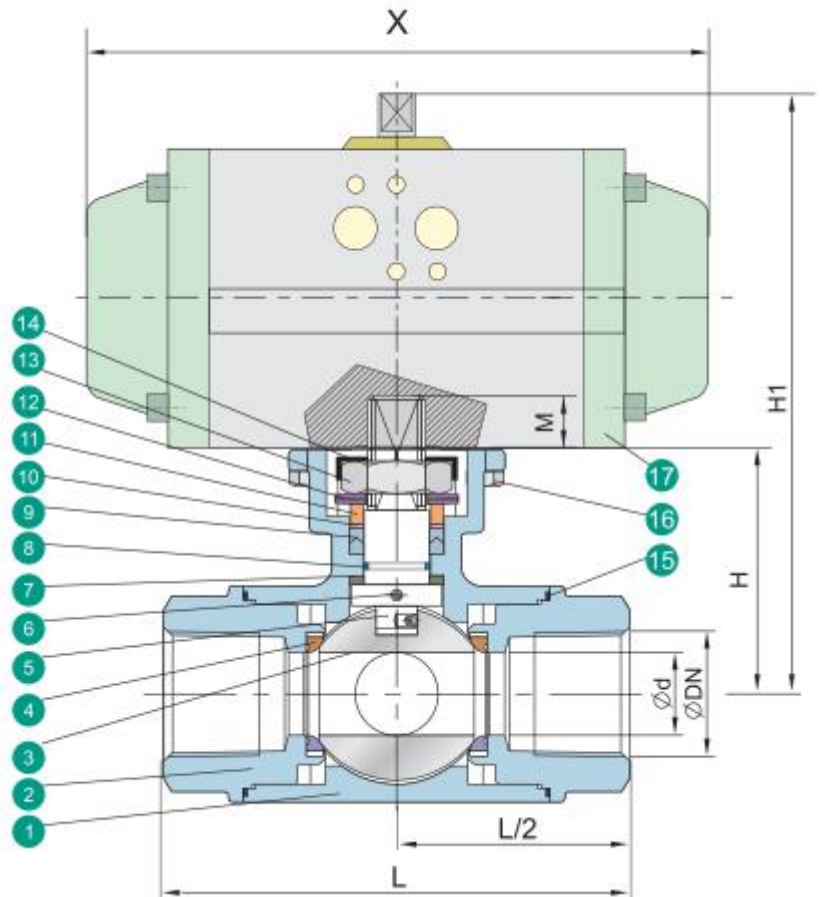

Beschreibung

- DN10-DN50 PN63
- 3-Way ball valve . threaded
- 3-Wege Kugelhahn (Schweissen)
- TA-LUFT design
- mit der Montagefläche nach ISO5211 für einfache Aumatisierung
- Qualität Präzisions-Gussteile
- schwimmende Kugel
- voller Durchgang
- Welle gegen Anregung gesichert

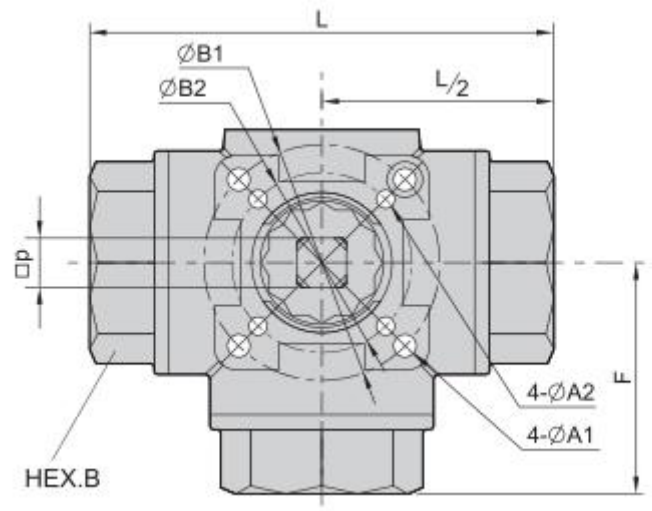
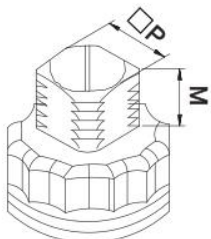
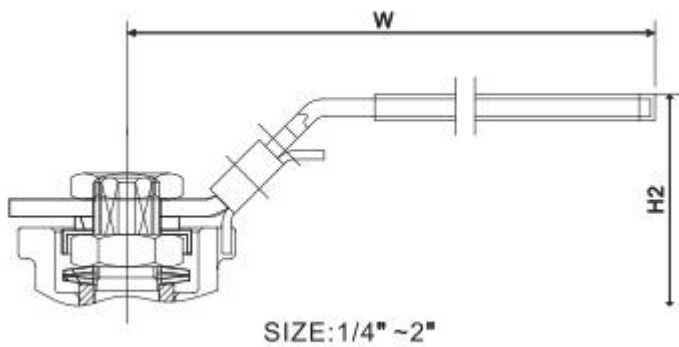

3-WEGE KUGELHAHN (Schweissen) DN 10 – 50 PN 63

Grösse

DN	Ød	L	H	H1	H2	W	M	F	ØB1	ØB2	ØA1	ØA2	P	HEX.B	X	ISO5211
8	11	79	42	139	70	147	9	40	42	36	6	6	9	27	144	F03-F04
10	11	79	42	139	70	147	9	40	42	36	6	6	9	27	144	F03-F04
15	11	79	42	139	70	147	9	40	42	36	6	6	9	27	144	F03-F04
20	15	88	49	146	77	147	9	44	50	36	7	6	9	34	144	F03-F05
25	20	108	60	188	87	177	11	54	50	42	7	6	11	41	208	F04-F05
32	25	124	63	191	93	177	11	62	70	42	9	6	11	50	208	F04-F07
40	32	135	74	216	103	215	14	68	70	50	9	7	14	56	247	F05-F07
50	40	164	83	225	113	215	14	82	70	50	9	7	14	70	247	F05-F07

Komponente

No.	Teil	Material		
1	Gehäuse	CF8M	CF8	WCB
2	Kappe	CF8M	CF8	WCB
3	Kugel	CF8M	CF8	
4	Kugelsitz	TFM1600/PTFE/RTFE		
5	Welle	SUS316	SUS304	
6	Antistatik	SUS316	SUS304	
7	Unterlage	PTFE		
8	O-Ring	FKM		
9	Wellepackung	PTFE		
10	Etui	50%SS + 50% PTFE		
11	Druckdichtung	SUS316		
12	Unterlage	SUS301		
13	Welle Mutter	A194-8		
14	Stopbuchse	SUS304		
15	Gehäusedichtung	PTFE		
16	Hex Schrauben	A193-B8		
17	Antrieb	Pneumatic/Electric		