

## BALL VALVE SERIE V-1FW DN15 – 50 PN40 DN65 – 150 PN16

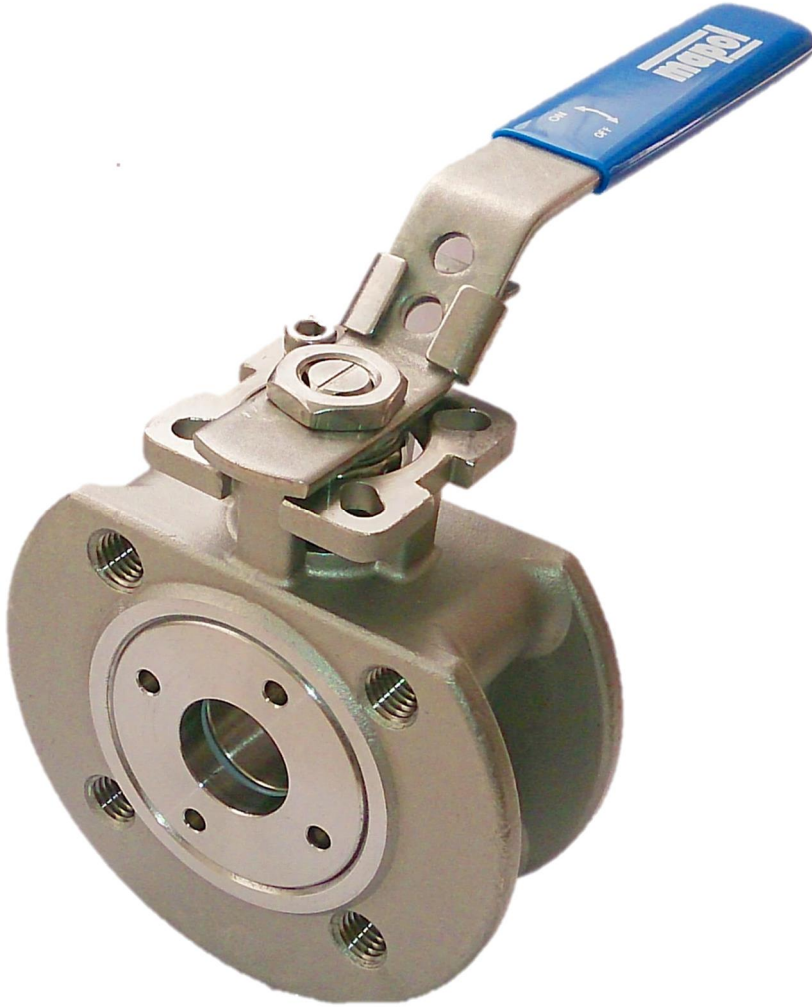

### Construction

- 2-piece construction
- full bore
- 1-piece body construction
- floating ball for good tightness
- shaft protected against firing
- maintenance-free
- die-casted
- FIRE-SAFE design
- TA-LUFT design

### Application

- DN15-DN50 PN40
- DN65-DN150 PN16
- working conditions acc to the chart
- for various industries

### Assembly

- in any position

Pressure/temperature chart

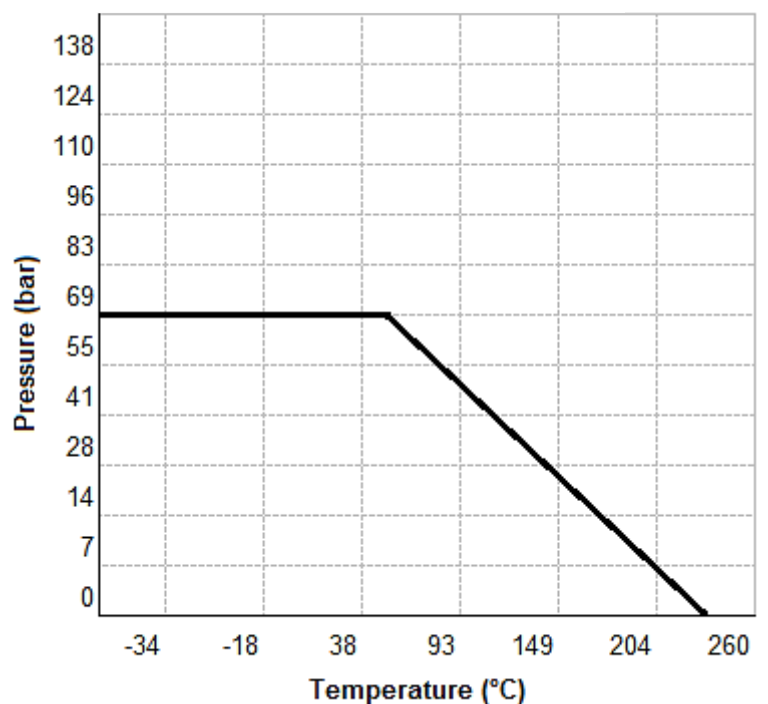

## BALL VALVE SERIE V-1FW DN15 - 50 PN40 DN65 - 150 PN16

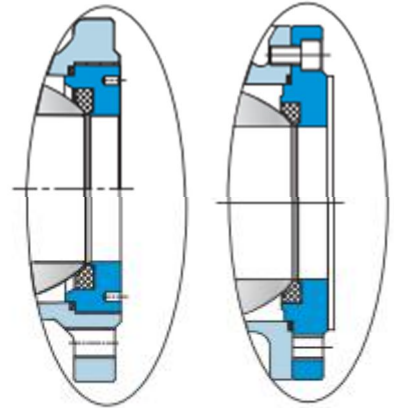
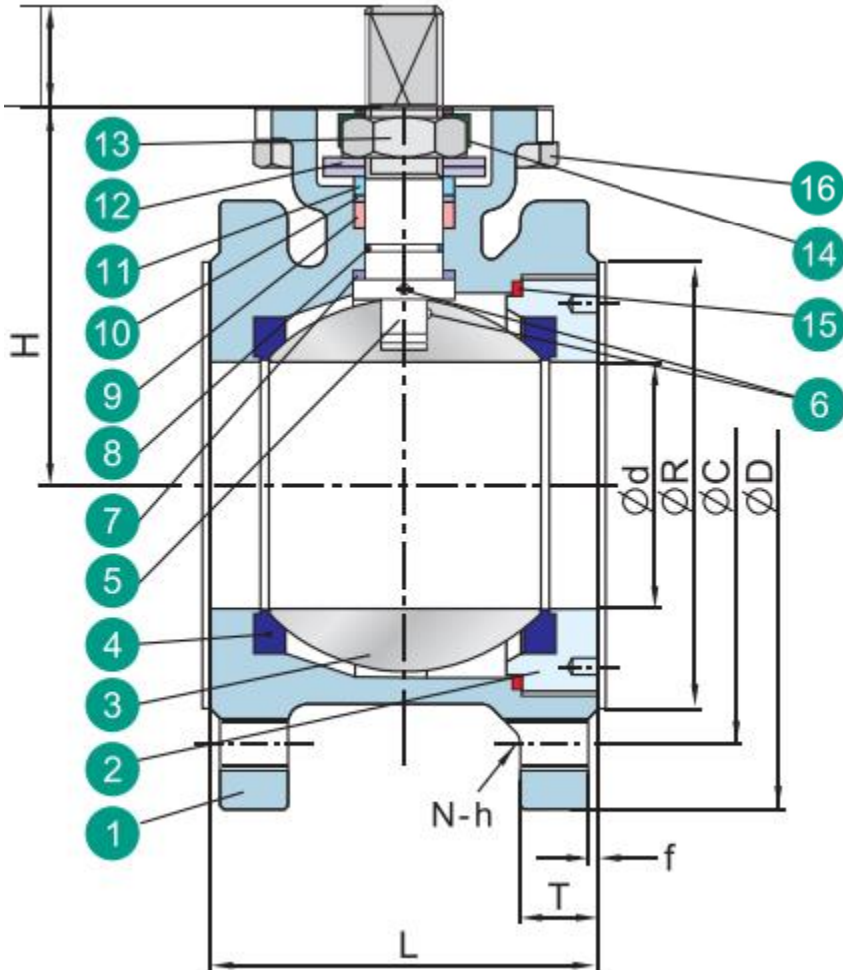

DN15 - DN80

DN100 - DN150

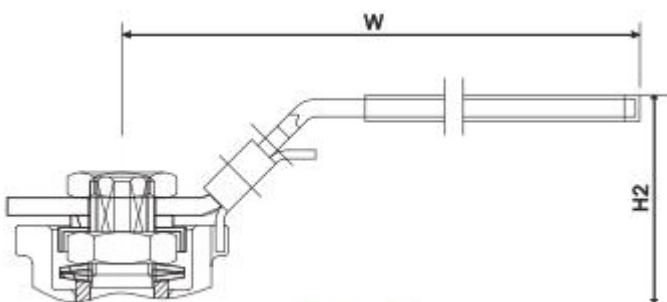

DN15 - DN80

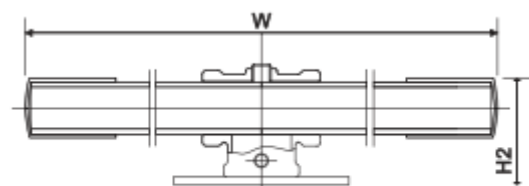

DN100 - DN150

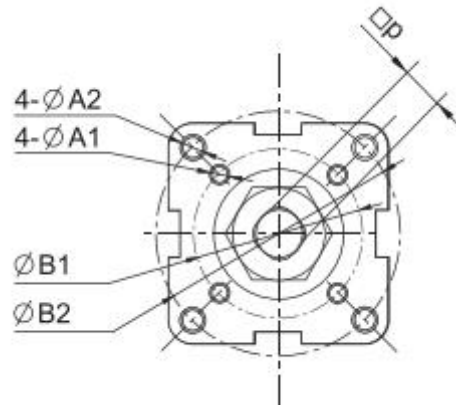
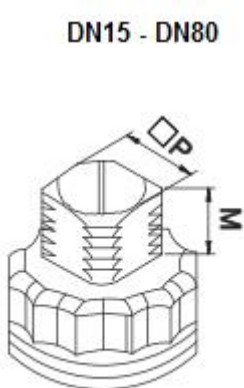



Elišky Přemyslovny 1343  
156 00 Praha 5, mapol@iol.cz

tel: +420 257 921 545, fax: +420 257 921 659

**BALL VALVE  
SERIE V-1FW  
DN15 – 50 PN40 DN65 – 150 PN16  
DIMENSIONS**

DN	PN	ød	R	C	D	f	T	L	H1	H2	W
15	10~40	15	45	65	95	2	9	42	143	77	145
20	10~40	20	58	75	105	2	9	44	148	85	145
25	10~40	25	68	85	115	2	9	50	172	94	175
32	10~40	32	78	100	140	2	12	60	182	104	175
40	10~40	38	88	110	150	3	13	65	206	114	196
50	10~40	50	102	125	165	3	20	80	214	120	196
65	10/16	63,5	122	145	185	3	18	110	250	158	265
	25/40						22	113			
80	10/16	76	138	160	200	3	20	120	340	165	265
	25/40						24				
100	10/16	95	158	180	220	3	20	150	334	182	400
	25/40		162	190	235		24	154			
125	10/16	118	188	210	250	3	22	180	407	224	800
	25/40			220	270		26				
150	10/16	142	212	240	285	3	22	225	423	268	800
	25/40		218	250	300		28				

H	M	P	N	h	ØA1	ØA2	ØB1	ØB2	X	ISO5211
46	9	9	4	M12	6	6	36	42	144	F03-F04
51	9	9	4	M12	6	7	36	50	144	F04-F05
62	11	11	4	M12	6	7	42	50	164	F04-F05
72	11	11	4	M16	6	9	42	70	164	F05-F07
78	14	14	4	M16	7	9	50	70	208	F05-F07
86	14	14	4	M16	7	9	50	70	280	F05-F07
108	17	17	4 8	M16	9	11	70	102	247	F07-F10
116	17	17	8	M16	9	11	70	102	268	F07-F10
439	22	22	8	M16 M20	n/a	11	n/a	102	345	F10
176	27	27	8	M16 M24	n/a	14	n/a	125	450	F12
192	27	27	8	M20 M24	n/a	14	n/a	125	545	F12



Elišky Přemyslovny 1343

156 00 Praha 5, mapol@iol.cz

tel: +420 257 921 545, fax: +420 257 921 659

**BALL VALVE**  
**SERIE V-1FW**  
**DN15 – 50 PN40 DN65 – 150 PN16**  
**MATERIALS**

#	Part	Materials		
1	Body	1.4408	1.4308	1.0619
2	Flange	1.4408	1.4308	1.0619
3	Ball	1.4408	1.4308	
4	Seat	TFM1600/PTFE/RPTFE		
5	Shaft	SUS316	SUS304	
6	Anti-static	SUS316	SUS304	
7	Washer	PTFE		
8	O-ring	FKM		
9	Shaft packing	PTFE/GRAFOIL*		
10	Bearing	50%SS+50%PTFE/SUS304*		
11	Packing	SUS316		
12	Disc washer	SUS304		
13	Shaft nut	A194-8		
14	Stop	SUS304		
15	Packing	PTFE/316 SPIRAL WOUND+GRAFOIL*		
16	Bolt	A193-B8		