(10)

-

«
» ISO 5211

(7)

-

(4)

-

(14)

-

(3,19)

PTFE

-

(11)

-

« - »

(5,6)

-

SS316

PTFE ,

(15)

-

ISO 5211

È

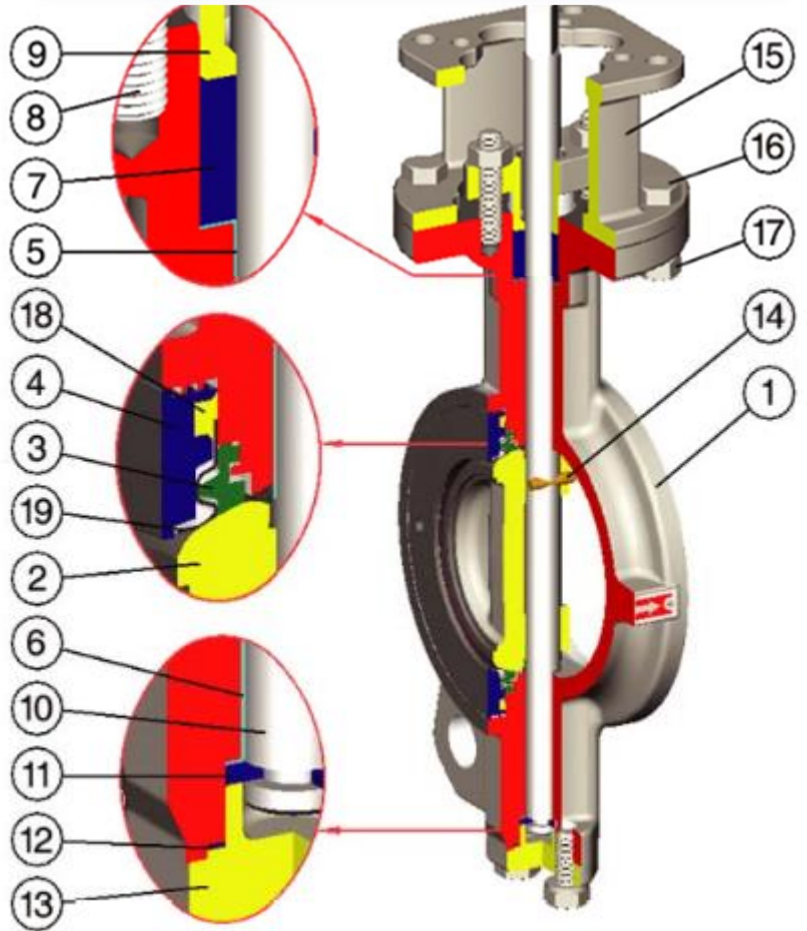

No				
1			A216 Gr. WCB	
		SS	A351 Gr. CF8	
			A351 Gr. CF8M	
			A351 Gr. CF3M	
2		SS	A351 Gr. CF8	
			A351 Gr. CF8M	
			A351 Gr. CF3M	
3		PTFE		-29°C - 160°C
		RPTFE		15%
		RPTFE		15%
4		SS	A351 Gr. CF8	
			A351 Gr. CF8M	
			A351 Gr. CF3M	
5		PTFE + SS316		
6		PTFE + SS316		
7				
8		SS	A193 Gr. B8	
9		SS	A351 Gr. CF8	
			A351 Gr. CF3M	
10		SS	A182 Gr. F6a	
			A182 Gr. F304	
			A182 Gr. F316	
			A564 Gr. 630	
			A479 Gr. XM-19	
11		SS	A240 Gr. 316	
12				
13		SS	A351 Gr. CF8	
			A351 Gr. CF8M	
			A351 Gr. CF3M	
			A216 Gr. WCB	24‰
14		SS	A182 Gr. F316	
15			A536 Gr. 65-45-12	optional
			A216 Gr. WCB	
		SS	A351 Gr. CF8	
16		SS	A193 Gr. B8	
17		SS	A194 Gr. 8	
18				
19		SS	A240 Gr. 316	