



### Hlavní výhody

- high performance klapka
- dvojitá excentricita uložení talíře
- oboustranná těsnost ve třídě 1 dle DN3230
- stavební délka: ISO 5752, tab.5-krátká
- doraz na tělese pro polohu zavěněno

### Dodávané typy

- VF-910 sedlo PTFE
- VF-920 kombinované sedlo  
(PTFE + kov = Fire - safe design)
- VF-930 kovové sedlo

### Montáž

Mezi průměry PN 10,16,25

Tlakovou třídou nutno upřesnit v objednávce

Doporučená poloha: s vodorovnou osou  
hřídele

Doporučený směr proudění je vpravo.

Přítomto způsobu montáže dosáhneme  
následujících výhod:

- minimální krouticí moment při otevírání
- menší opotřebení sedla
- v zavěněném stavu není pracovní látka  
v kontaktu se sedlem

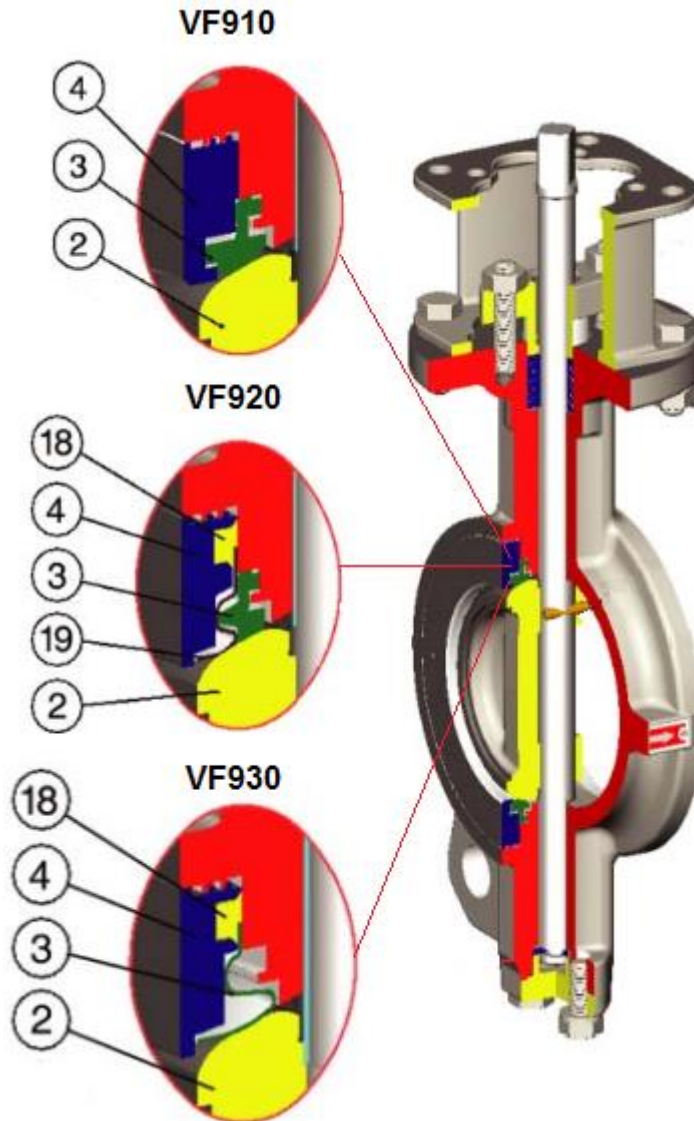

č.	Název	Materiál	Označení dle ASTM	Poznámka
2	Talí	Nerezová ocel	A351 Gr. CF8	dosedací plocha talí e je tvrd chromovaná
			A351 Gr. CF8M	
			A351 Gr. CF3M	
3	Kovové sedlo	Nerezová ocel	A240 Gr. 316	
4	P íruba sedla	Nerezová ocel	A351 Gr. CF8	
			A351 Gr. CF8M	
			A351 Gr. CF3M	
18	Ucpávka sedla	Grafit		
19	Podložka	Nerezová ocel	A240 Gr. 316	

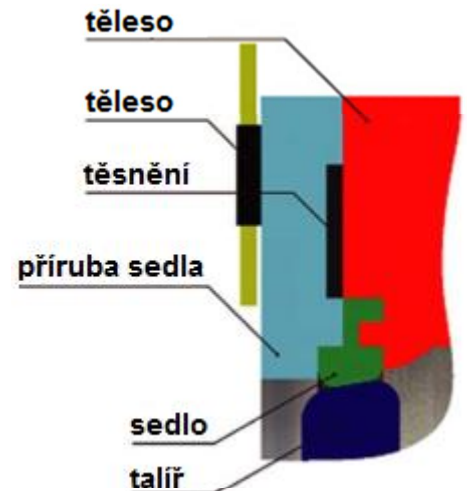
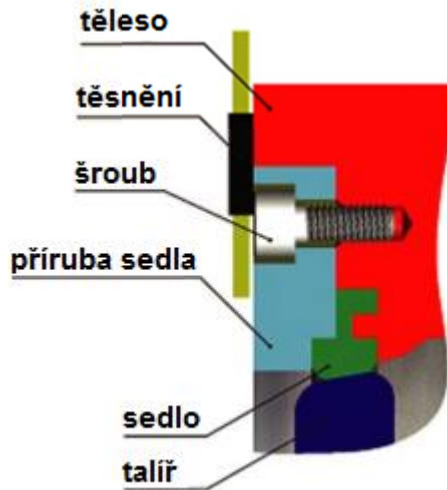
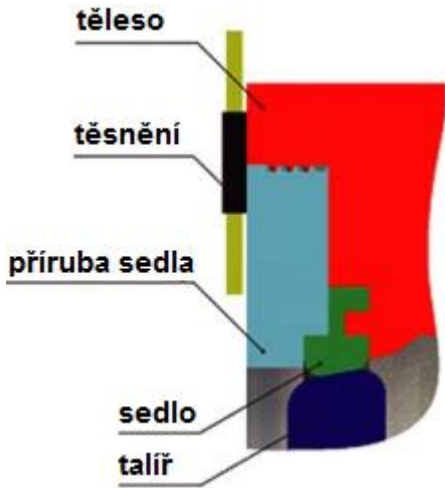

Koeficient pr toku  $K_v$  závislosti  
na úhlu nato ení talí e

DN	10°	20°	30°	40°	50°	60°	70°	80°	90°
65	1	11	27	40	60	83	106	133	140
80	2	20	50	73	110	154	200	250	260
100	4	32	80	120	180	250	320	400	420
125	7	55	140	200	300	430	550	680	720
125	11	90	230	340	510	710	910	1140	1200
200	20	150	390	560	850	1190	1520	1900	2000
250	30	240	600	870	1310	1840	2360	2940	3100
300	40	360	920	1330	2000	2800	3600	4500	4750
350	55	450	1130	1640	2500	3500	4500	5500	5850
400	75	650	1600	2300	3500	4900	6300	7850	8300
450	95	800	2000	2900	4400	6100	7900	9900	10400
500	125	1000	2700	3900	5900	8200	10500	13000	13800
600	200	1700	4400	6300	9500	13300	17000	21300	22500

Únosnost sedla v závislosti  
tlak/teplota

Temp °C	PTFE	RPTFE
-29 do 38	19,6	19,6
66	18,8	18,8
93	17,9	17,9
121	16,9	16,9
149	15,8	15,8
177	14,8	9,6
204	6,9	3,4
232	0	0

Diagram tlak/teplota

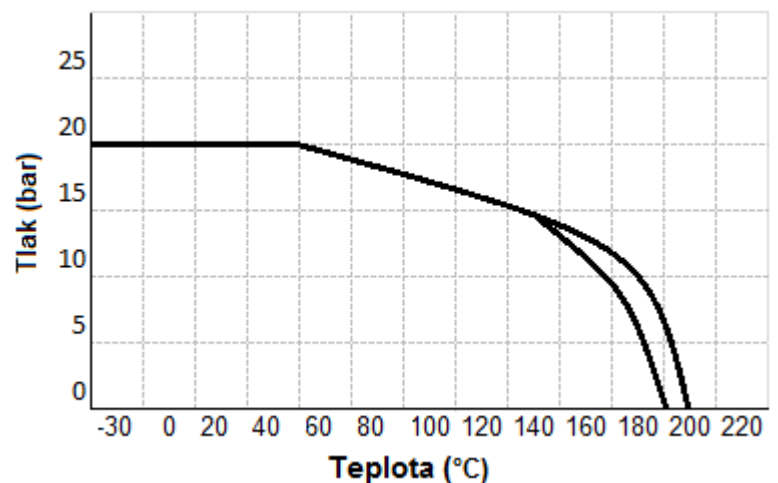

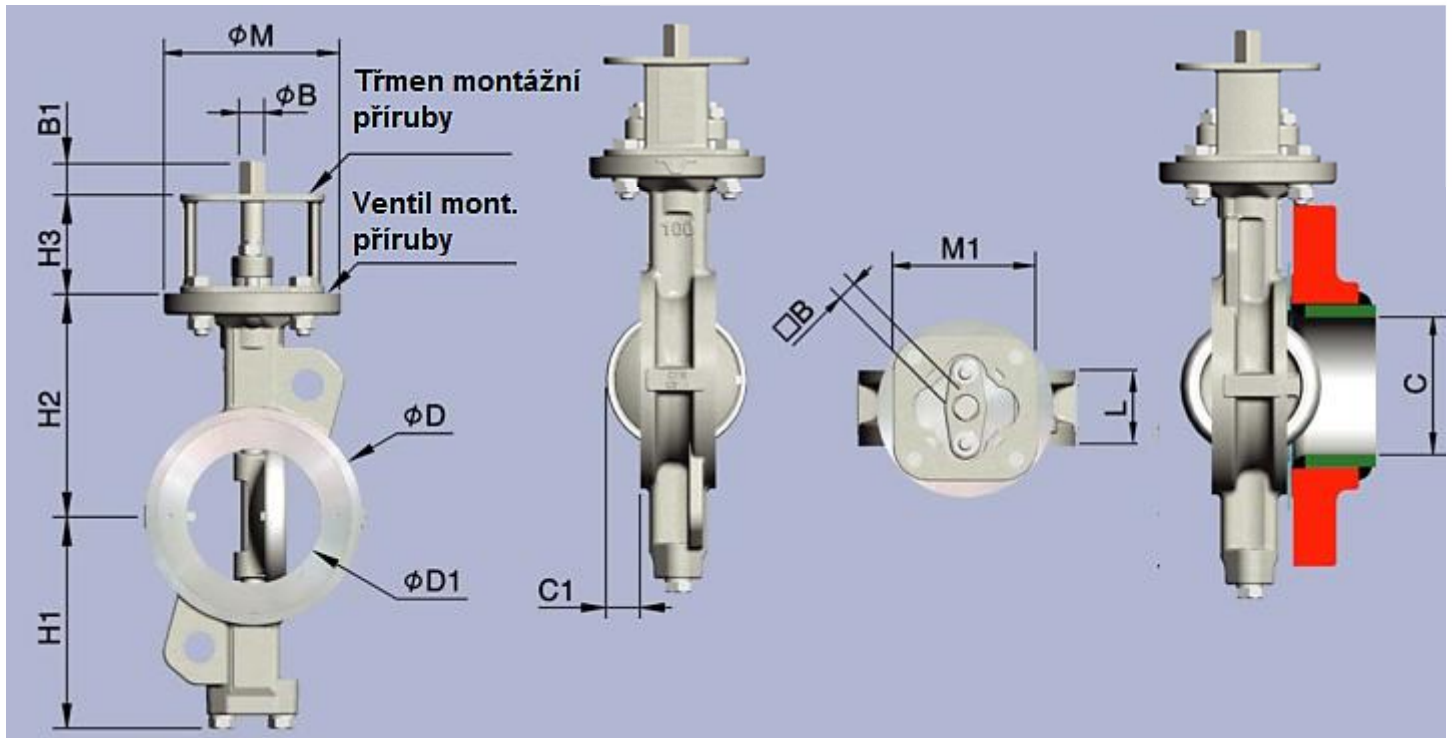

DN	stav.délka	Rozměry							P íruba dle ISO 5211				Konec h ídele			Hmotnost	
		L	H1	H2	H3	øD	øD1	C	C1	Klapka		T men		øM	B		B1
50	43	99	118	60	92	37	49,5	2	F07	90	F07	F05	70	14	11	18	3,9
65	46	110	125	60	108	63	62	15	F07	90	F07	F05	70	14	11	18	4,5
80	47	128	140	70	126	78	78	22	F10	125	F10	F07	102	18	14	23	7
100	53	150	157	70	153	95	93	25	F10	125	F10	F07	102	18	14	23	9
125	57	163	170	70	184	118	120	36	F10	125	F10	F07	102	22	17	23	12
150	56	176	185	70	212	143	149	50	F10	125	F10	F07	102	22	17	23	13,5
200	62	206	220	80	268	188	196	70	F12	150	F12	F10	125	25	19	28	22
250	68	238	250	80	326	236	243	90	F12	150	F12	F10	125	28	22	28	32
300	78	269	290	100	375	282	259	106	F14	175	F14	F12	160	35	27	37	48
350	78/92	306	326	100	416	322	329	125	F14	175	F14	F12	160	36	27	37	66
400	102	342	370	120	476	371	377	140	F16	210	F16	F14	195	48	36	47	107
450	114	370	395	120	534	418	423	157	F16	210	F16	F14	195	48	36	47	130
500	127	399	430	120	588	466	471	177	F16	210	F16	F14	195	60	46	56	163
600	154	455	490	150	692	570	572	210	F25	300	F25	F16	300	60	46	56	278



**UZAVÍRACÍ KLAPKA**  
 TYP VF910,920,930,913,923,933  
 DN 50 – 600 PN 10 – 25  
 Ovládání s pákou nebo převodovkou

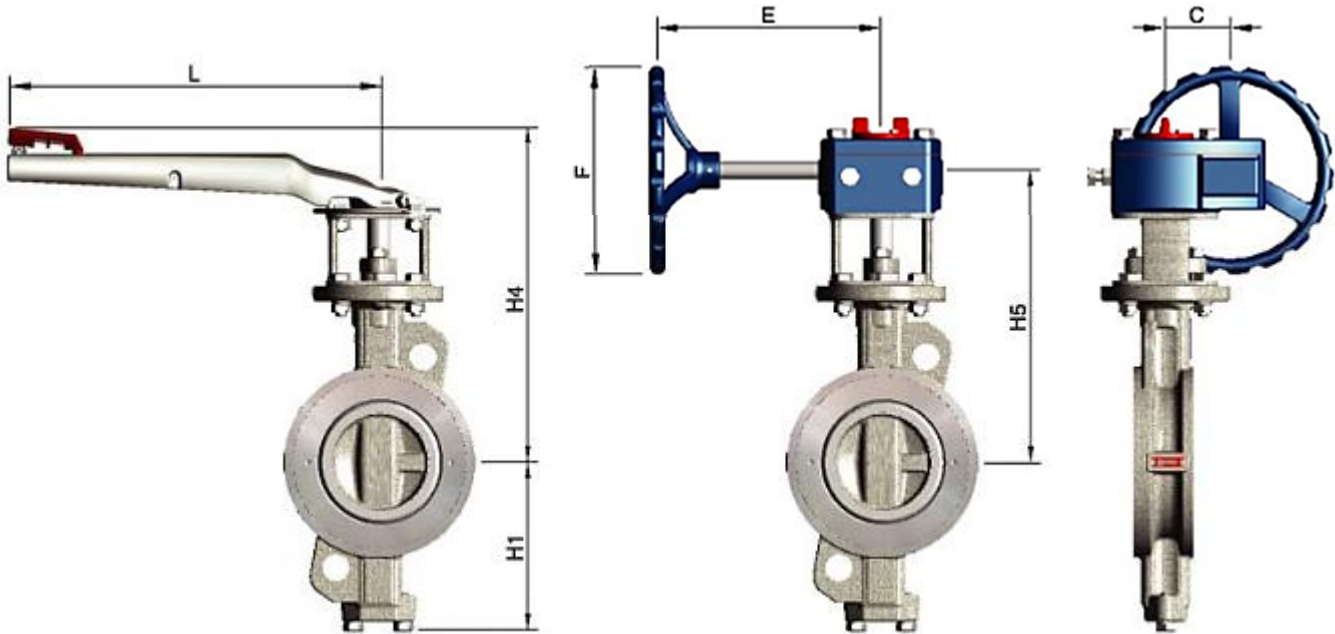

DN	S pákou				Se ýnekovou p evodovkou					
	Rozm ry		Hmotnost (kg)		Rozm ry				Hmotnost (kg)	
	H4	L			H5	C	E	F		
65	257	200	5,2	6,2	-	-	-	-	-	-
	-	-	-	-	222	41	155	150	7,8	8,8
80	282	250	7,8	9,3	-	-	-	-	-	-
	-	-	-	-	247	41	155	150	10,3	11,8
100	299	250	9,8	14,8	-	-	-	-	-	-
	-	-	-	-	296,5	63	195	200	16,5	21,5
125	318	355	13,6	19,6	-	-	-	-	-	-
	-	-	-	-	281,5	63	195	200	19,5	25,5
150	333	355	15,1	21,1	-	-	-	-	-	-
	-	-	-	-	296,5	63	195	200	21	27
200	378	355	23,6	32,6	-	-	-	-	-	-
	-	-	-	-	341	61	232	310	31	40
250	-	-	-	-	381	61	232	310	41	56
300	-	-	-	-	443	81	280	400	70	89
350	-	-	-	-	479	81	280	400	88	103
400	-	-	-	-	546	123	307	400	142	178
450	-	-	-	-	571	123	307	400	165	198
500	-	-	-	-	606	123	307	400	198	265
600	-	-	-	-	785	160	370	400	387	488



## UZAVÍRACÍ KLAPKA TYP VF910,920,930,913,923,933 DN 50 – 600 PN 10 – 25 Montáž a tabulku přířubových spojů

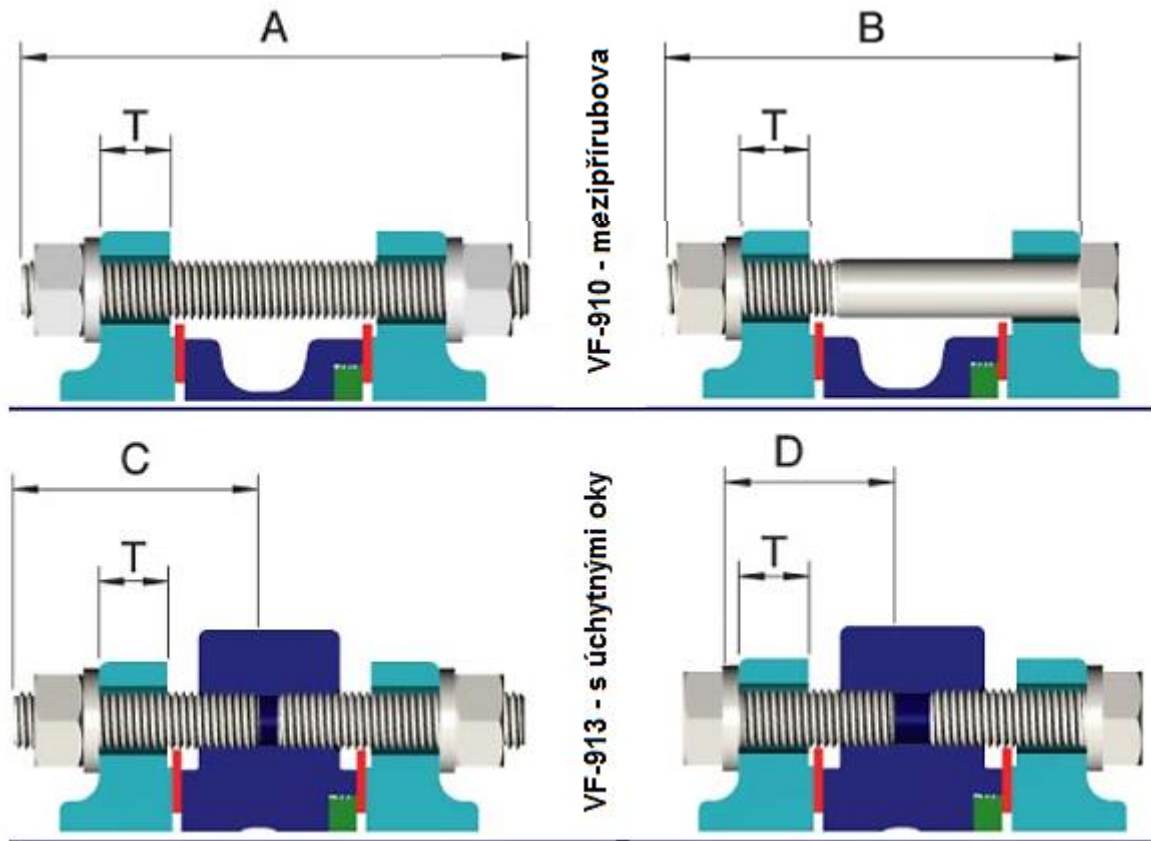

DN	PN 10						PN 16						PN 25					
	ýroub	A	B	C	D	T	ýroub	A	B	C	D	T	ýroub	A	B	C	D	T
50	M16	135	120	65	45	20	M16	130	120	65	45	20	M16	130	125	70	50	22
65	M16	135	120	70	45	20	M16	135	120	70	45	20	M16	140	125	70	50	22
80	M16	135	120	70	45	20	M16	135	120	70	45	20	M16	145	130	75	50	24
100	M16	145	130	75	50	22	M16	145	130	75	50	22	M20	160	140	80	55	24
125	M16	150	135	75	50	22	M16	150	135	75	50	22	M24	180	155	90	60	26
150	M20	165	140	80	55	24	M20	165	140	80	55	24	M24	180	155	90	60	28
200	M20	165	145	85	55	24	M20	165	145	85	55	24	M24	190	165	95	65	30
250	M20	180	160	90	60	26	M24	190	165	95	60	26	M27	210	180	105	70	32
300	M20	190	170	95	65	26	M24	205	180	100	70	28	M27	220	195	110	75	34
350	M20	190	170	95	65	26	M24	210	185	105	70	30	M30	235	205	120	80	38
400	M24	225	200	110	70	26	M27	240	215	120	80	32	M33	270	240	135	95	40
450	M24	240	215	120	75	28	M27	270	240	135	90	40	M33	300	265	150	105	48
500	M24	255	230	125	75	28	M30	300	270	150	100	44	M33	310	280	155	105	48
600	M27	300	270	150	85	34	M33	355	320	175	110	54	M36	330	330	185	120	58



**UZAVÍRACÍ KLAPKA**  
 TYP VF910,920,930,913,923,933  
 DN 65 – 600 PN 10 – 25  
 Těleso s úchytnými oky - rozměry

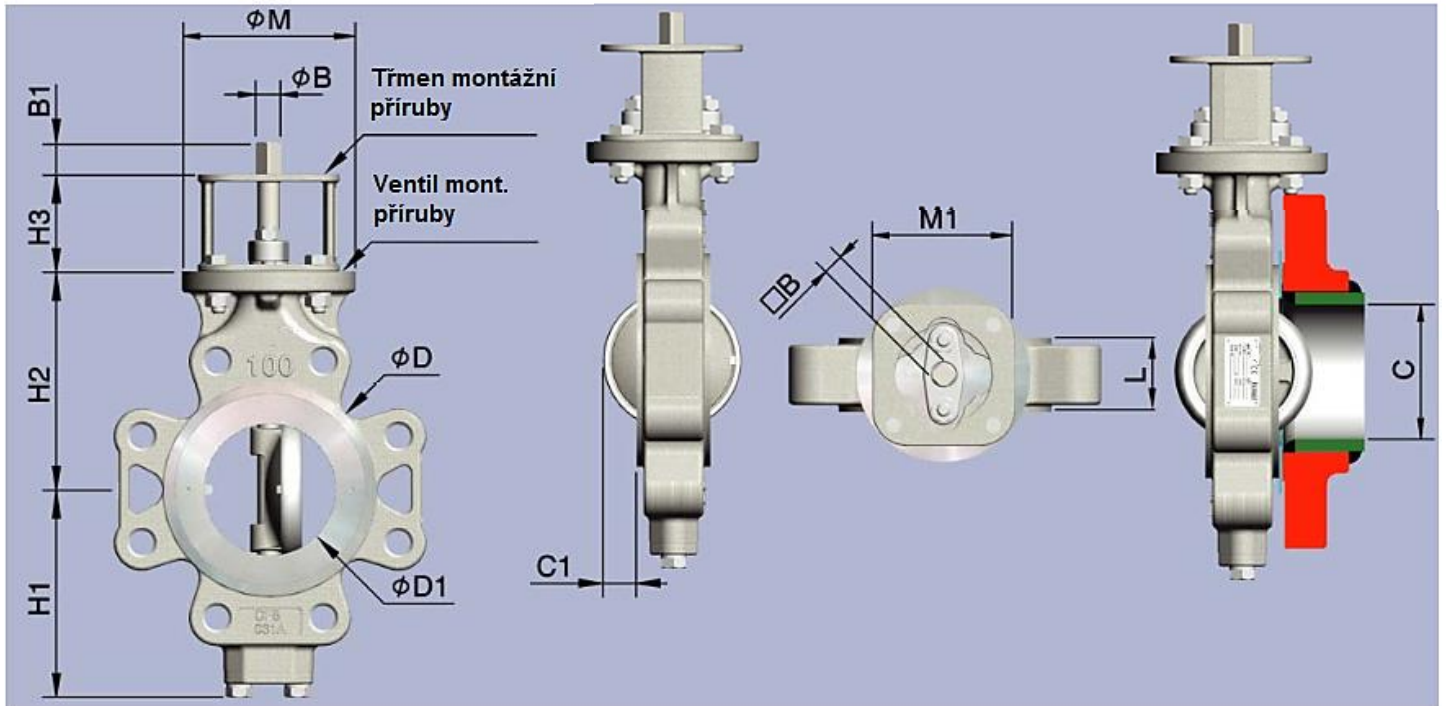

DN	stav.délka	Rozměry							Příruba dle ISO 5211				Konec hřídele			Hmotnost kg	
		L	H1	H2	H3	$\phi D$	$\phi D1$	C	C1	Klapka		Těmen		$\phi B$	B		B1
										$\phi M$			M1				
50	43	99	118	60	92	37	49,5	2	F07	90	F07	F05	70	14	11	18	4,9
65	46	110	125	60	108	63	62.3	15	F07	90	F07	F05	70	14	11	18	5,5
80	47	128	140	70	126	78	78	22	F10	125	F10	F07	102	18	14	23	8,5
100	53	150	157	70	153	95	93	25	F10	125	F10	F07	102	18	14	23	14
125	57	163	170	70	184	118	120	36	F10	125	F10	F07	102	22	17	23	18
150	56	176	185	70	212	143	149	50	F10	125	F10	F07	102	22	17	23	19,5
200	62	206	220	80	268	188	196	70	F12	150	F12	F10	125	25	19	28	31
250	68	238	260	80	326	236	243	90	F12	150	F12	F10	125	28	22	28	47
300	78	269	290	100	375	282	289	106	F14	175	F14	F12	160	35	27	37	67
350	78/92	306	326	100	416	322	329	125	F14	175	F14	F12	160	36	27	37	81
400	102	342	370	120	476	371	377	140	F16	210	F16	F14	195	48	36	47	143
450	114	370	395	120	534	418	423	157	F16	210	F16	F14	195	48	36	47	163
500	127	399	430	120	588	466	471	177	F16	210	F16	F14	195	60	46	56	230
600	154	455	490	150	692	570	572	210	F25	300	F25	F16	300	60	46	56	377